



FONTA

DRY DECK FOUNTAIN SET
SLAB HANGER VERSION

DRY DECK FOUNTAIN SET SLAB HANGER VERSION

Full stainless steel Water switching Dry deck set brings endless water and light effects. Can be equipped with different nozzles and controlled via DMX.

This water switch works in different way, problem free way. Hi flow with low resistance - very good LPM to Head ratio.

Switch normally directs water to nozzle. When 24VDC signal opens discharge valve, water flow is redirected to waste and flows under switching unit body. No usual solenoid valves that shuts water flow and can cause water hammer. No small ports, diverting mechanical parts and small channels that are usual for water switches and gets stuck time after time.

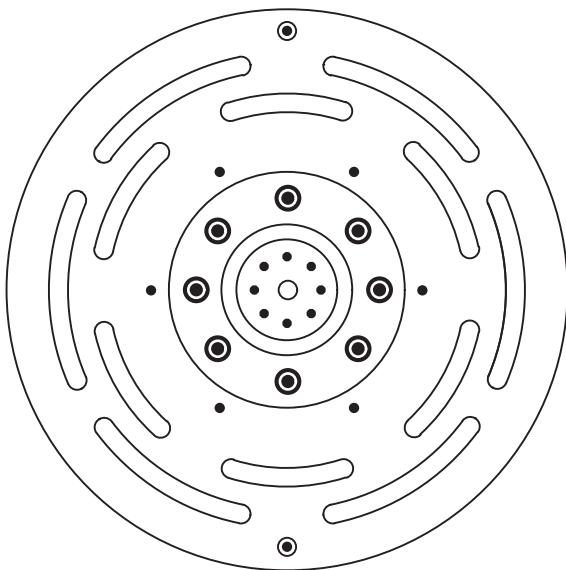

300 mm

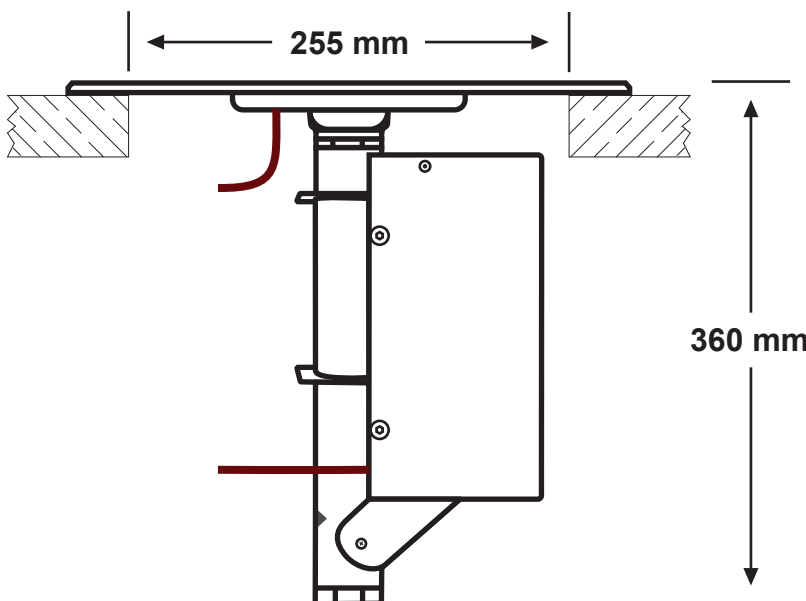

255 mm

360 mm

Advantages:

- Durable, reliable, no maintains required
- Nozzles has easy adjustable angle option
- Can operate hi water jets up to 110 LPM
- Switching unit has low requirements for water quality
- No water hammer fault possibility
- No micron filter is required
- No need for hi pressure pumps to achieve hi nozzle jets

Cover options

- Shape can be round or square
- Outer diameter can be custom size
- Right edge or beveled edge
- 304 or 316 grade steel
- 5 or 6 mm thickness

Lighting options

- Round 27W or twin 9W lights
- RGB or single color
- DMX control

Compatible nozzles

- Clear Jet (orifice can be 12 to 20 mm)
- Multi Jet (custom hole quantity and size)
- Foaming Jet



FONTA

**DRY DECK FOUNTAIN SET
SLAB HANGER VERSION**



12mm Smooth Nozzle

M	Bar.	Head	LPM
0.5	0.15	1.50	28
1	0.2	2.00	35
1.5	0.35	3.50	42
2	0.45	4.50	45
2.5	0.55	5.50	52
3	0.65	6.50	55
3.5	0.75	7.50	61
4	0.85	8.50	64

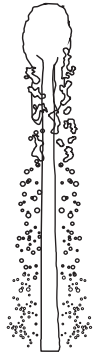

Foaming Nozzle

M	Bar.	Head	LPM
1	0.4	4.00	37
1.5	0.5	5.00	54
2	0.65	6.50	61
2.5	0.76	7.60	68
3	0.85	8.50	71
3.5	0.96	9.60	78
4	1.07	10.70	85

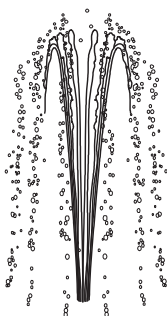

Multi Jet Nozzle

M	Bar.	Head	LPM
0.5	0.2	2.00	35
1	0.35	3.50	43
1.5	0.44	4.40	51
2	0.6	6.00	59
2.5	0.75	7.50	67
3	0.9	9.00	74
3.5	1.05	10.50	81



CONNECTION DIAGRAM

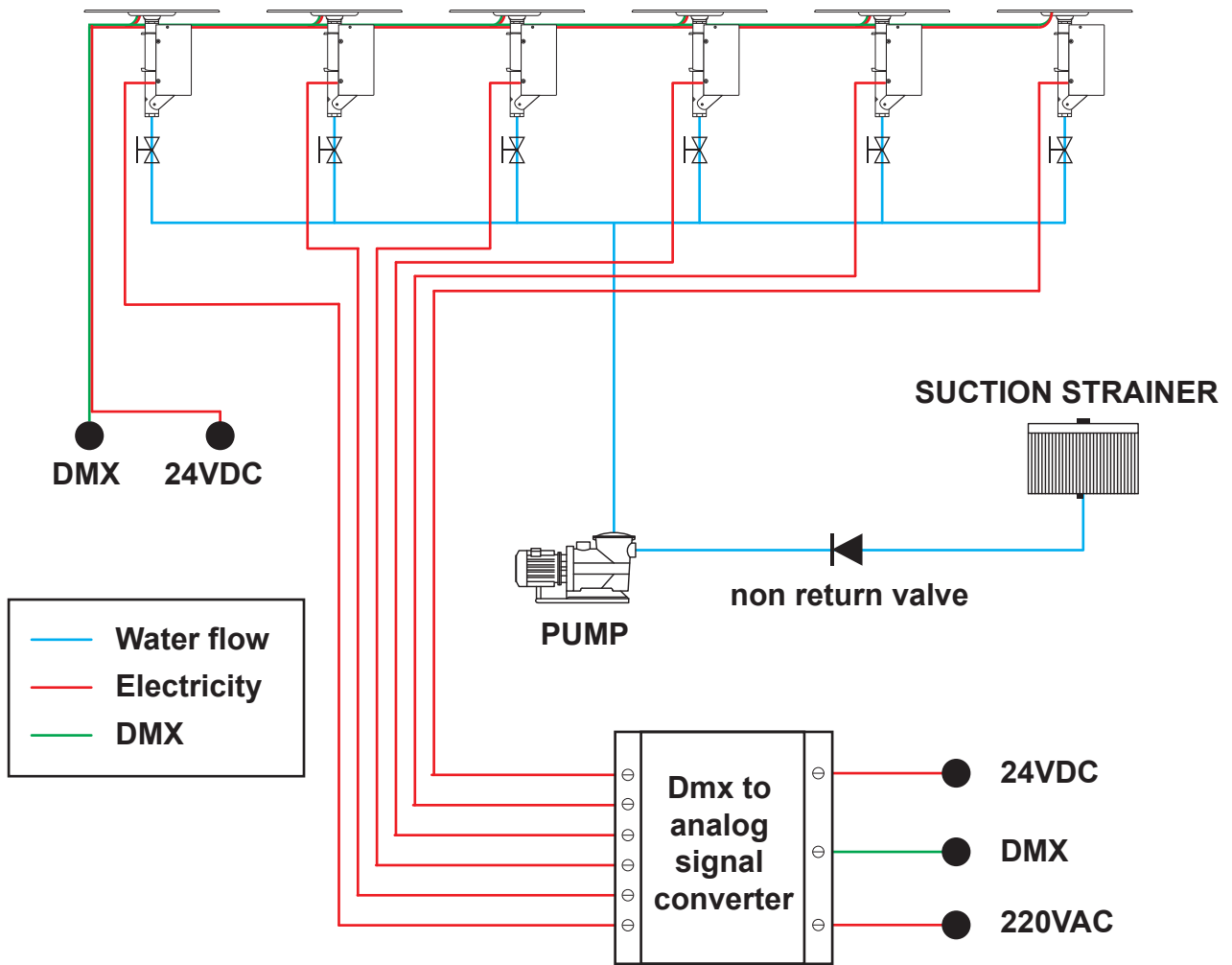

SWITCH SPECIFICATION

- 24VDC 30W bipolar connection switching mechanism
- 24VDC LED Lights
- Switching up to 10 times/sec.
- Switching unit operates water flow up to 110 LPM
- 1" connection
- All stainless steel body parts
- Switching unit is water level independent, also can work underwater
- Depend on chosen nozzle, required suction strainer filter 2-3mm